

TECPACK AUTOMATION Pvt Ltd
Total Packing Solutions & Industrial Automation

We are manufacturer of:

- Total Primary Packaging M/C
- Total Secondary Packaging M/C
- All type of Industrial Automation
- Packaging Automation
- Special Purpose M/C
- All type of Conveyor

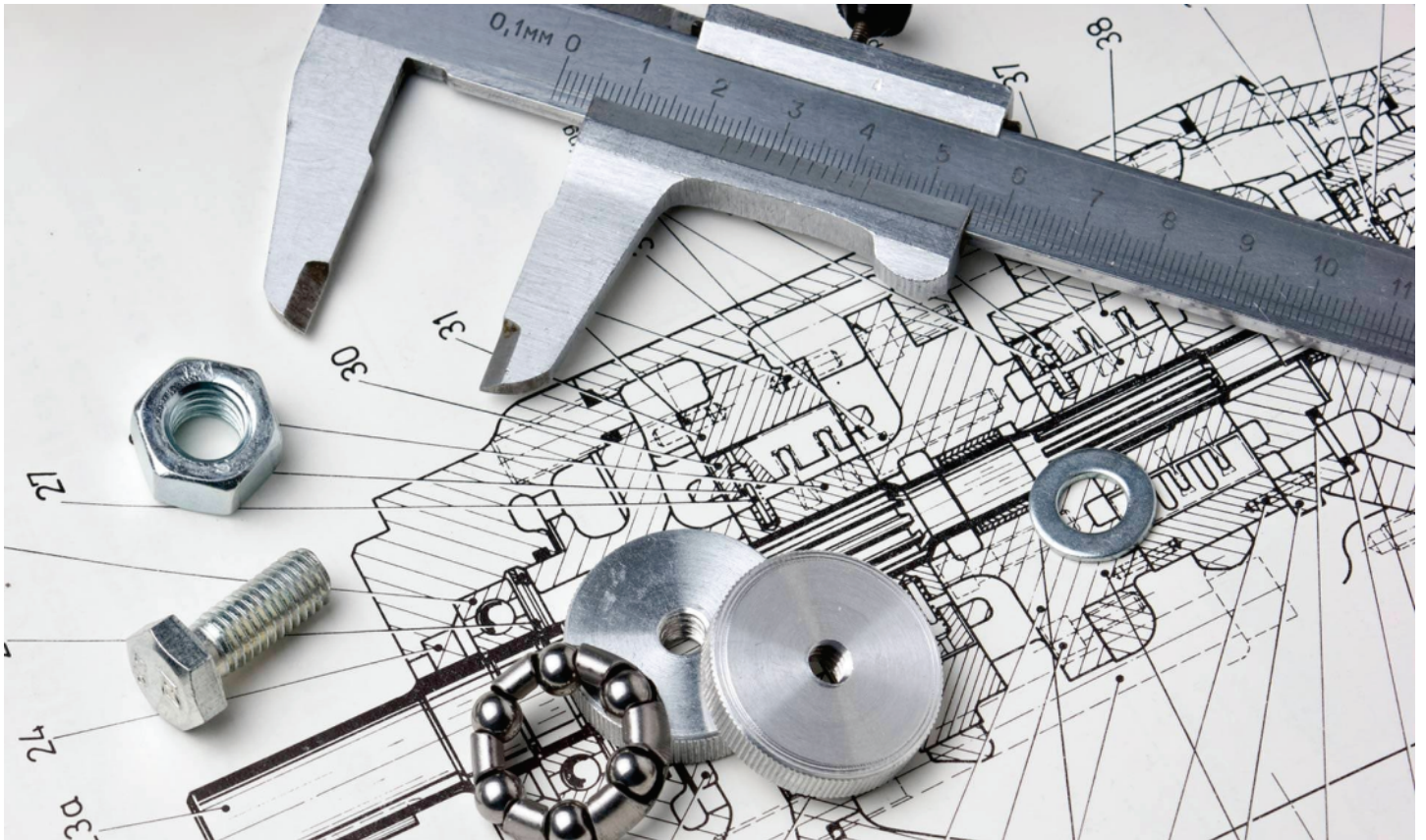



Established in the year 2011, at Pune (Maharashtra, India), We, "B.N. Enterprises." is the manufacturer, trader and exporter of a wide range of Wrapping Machine, Shrink Tunnel, Control Panel Board, L-Sealer Machine, Sealing Machine, Industrial Conveyor etc.

Our skilled team designs and manufactures these products using premium quality raw material, sourced from the well-established vendors of the industry. Offered products are widely demanded and appreciated by our precious clients, owing to the features like low operating cost, low maintenance, fine finish, optimum quality, durability and reliability. We manufacture these products in compliance with the set international quality standards in our high-tech manufacturing unit. Our precious clients can avail these products in various specifications as per their specific requirements and at highly competitive prices.

Our mentor, Mr. Choure B., has guided us to be able to famous in this domain. Our zeal has enabled us to carve a niche in this industry...



In 2011, we start shrink packaging researching and manufacturing from following models, such like manual models, semi-automatic models and constant shrink tunnel.

In 2012, we start to manufacture combination models independently;

In 2014, ST-series sleeve wrapper and POF shrink tunnel are successfully developed;

In 2015, we manufacture Frontal feeding automatic sleeve wrapper ST-6030X, ST-6030Z and monolithic POF folding system;

In 2016, we break the traditional technology on L-bar sealer, and manufactured the 1st automatic L-bar sealing FL-5545TBA at domestic market; we start to manufacture high speed side sealing system and shrinking tunnel FL-5545TBH+SM-5030LX, which combined Germany type on technology and design; we manufactured the 1st Vertical automatic L sealer FL-5545TBD at domestic market; we developed high speed continues motion sealer system FL5545TBJ, flower wrapper FL5545TBI+SM-2020, and automatic high speed feeder system FL-5545TBK. We do manufacture all type of primary and secondary packaging machines with focused Industrial Automation.



MARKET SHARE

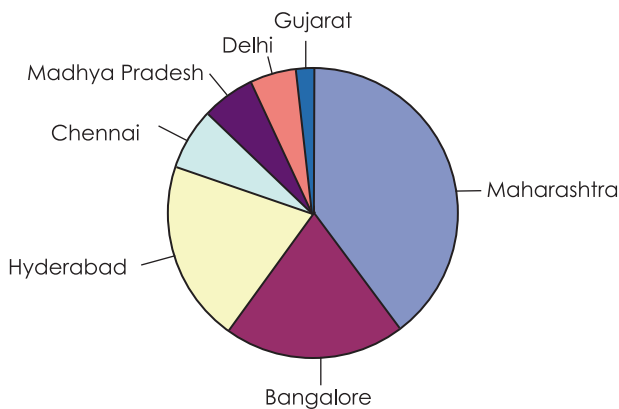

QUANTITY OF SCALE

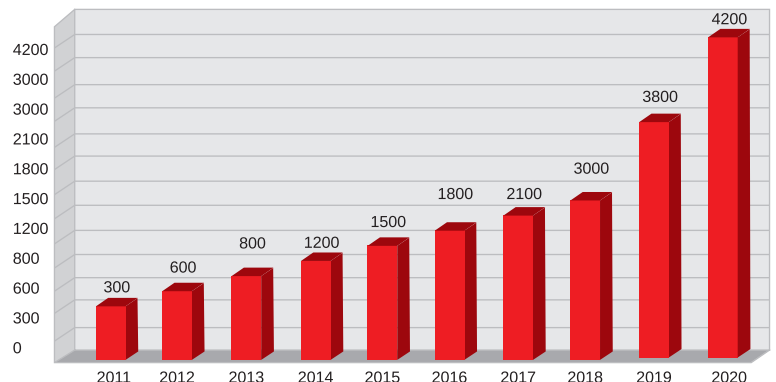



We are proudly in providing our related equipments and service for some famous manufactories both home and aboard. Here we are special thanks for these following customers (we can not list all of them because there are too many, so we take our regarding together by this opportunity.)



1-10. SEMI AUTO LIQUID FILING MACHINE PNEUMATIC OPERATED

(Use for Viscosity for Water to Honey Level)

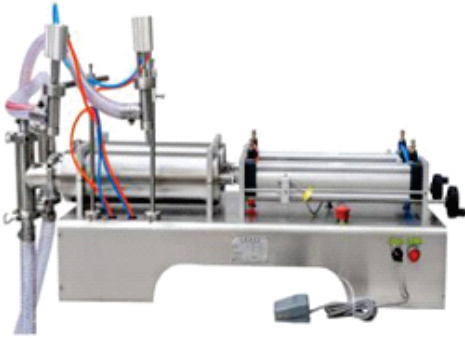

MODEL	BNTPALF: 10-100 ML -GM 1HP/ 2HP	BNTPALF:50-500 ML -GM 1HP/2HP	BNTPALF:100-1000 ML -GM 1HP/ 2HP	BNTPALF:500-5000 ML -GM 1HP/2HP
POWER	20w -50w 230 ac 50hz	20w -50w 230 ac 50hz	20w -50w 230 ac 50hz	20w -50w 230 ac 50hz
AIR PRESSURE	4 to 6 bar	4 to 6 bar	4 to 6 bar	4 to 6 bar
FILLING SPEED	5-10 -10 -20 bottles/min	5-10 -10 -20 bottles/min	5-10 -10 -20 bottles/min	5-10 -10 -20 bottles/min
FILLING ACCURACY	≤±1-2% ml-gm	≤±1-2% ml-gm	≤±1-2% ml-gm	≤±1-2% ml-gm

(USE FOR VISCOSITY FOR
WATER TO EDIBLE OIL LEVEL)

MODEL	BNE4000-MLT-1HE	BNE4000-MLT-2HE
POWER	100w-230 v ac hz50	200w-230 v ac hz50
FILLING SPEED	5-10 bottles/min	5-10 bottles/min
FILLING ACCURACY	≤±1-2% ml	≤±1-2% ml

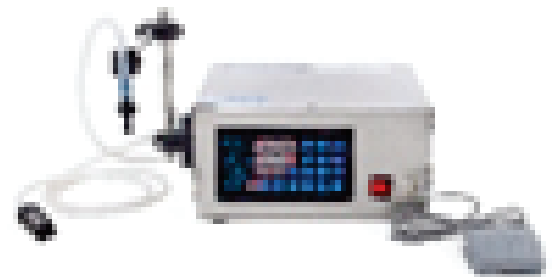

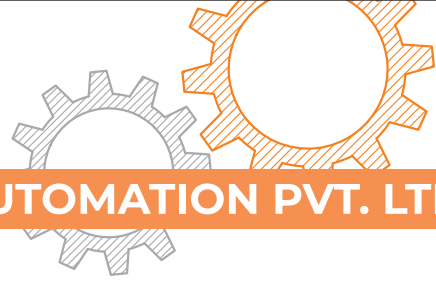

SEMI AUTO PASTE FILLING MACHINE PNEUMATIC OPERATED

(USE FOR VISCOSITY FOR WATER TO PASTE LEVEL)



MODEL	BNTPAPF:10-100- GM -ML1H/ML2H	BNTPAPF: 50-500-GM -ML1H/ML2H	BNTPAPF: 100-1000-GM -ML1H/ML2H	BNTPAPF:500-5000-GM -ML 1H/2H
POWER	20w- 50 w 230 v ac 50 hz	20w- 50 w 230 v ac 50 hz	20w- 50 w 230 v ac 50 hz	20w- 50 w 230 v ac 50 hz
AIR PRESSURE	4 to 6 bar	4 to 6 bar	4 to 6 bar	4 to 6 bar
FILLING SPEED	5-10 -10 -20 bottles/min	5-10 -10 -20 bottles/min	5-10 -10 -20 bottles/min	5-10 -10 -20 bottles/min
FILLING ACCURACY	≤±1-2%	≤±1-2%	≤±1-2%	≤±1-2%
HOPPER VOLUME	15-20 l/kg	15-20 l/kg	15-20 l/kg	15-20 l/kg



MODEL	BNTPA: 50M ML -GM 1HP	BNTPA: 100M ML -GM HP	BNTPA: 50P ML -GM 1HP	BNTPA: 100P ML -GM 1HP
OPERATING	manual operated	manual operated		
AIR PRESSURE			4 to 6 bar	4 to 6 bar
FILLING SPEED	5-10 bottles/min	5-10 bottles/min	5-10 bottles/min	5-10 bottles/min
FILLING ACCURACY	≤±1-2% ml-gm	≤±1-2% ml-gm	≤±1-2% ml-gm	≤±1-2% ml-gm
HOPER CAPACITY	5 kg	5 kg	5 kg	5 kg

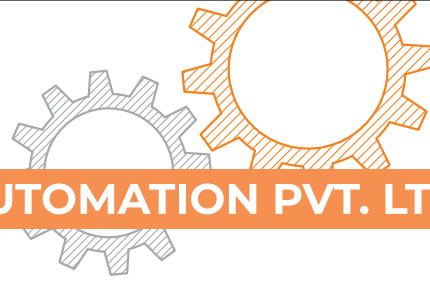

FULLY AUTOMATIC PNEUMATICS OPERATED LIQUID MACHINE

(USE FOR VISCOSITY FOR WATER TO HONEY LEVEL)

B N ENTERPRISES

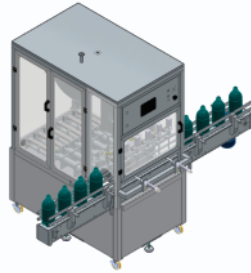

MODEL	BNTPALF: 10-100 ML-GM 2H-4H-6H-8H-10H-12H	BNTPALF:50-500 ML -GM 2H-4H-6H-8H-10H-12H	BNTPALF:100-1000 ML -GM 2H-4H-6H-8H-10H-12H	BNTPALF:500-5000 ML -GM 2H-4H-6H-8H-10H-12H
POWER	1.2 kw 230 ac 50hz	1.2 kw 230 ac 50hz	1.2 kw 230 ac 50hz	1.2 kw 230 ac 50hz
AIR PRESSURE	4 to 6 bar	4 to 6 bar	4 to 6 bar	4 to 6 bar
FILLING SPEED	10-15,25-30,35-40,45-50, 55-60,70-80 bpm	10-15,25-30,35-40,45-50, 55-60,70-80 bpm	10-15,25-30,35-40,45-50, 55-60,70-80 bpm	10-15,25-30,35-40,45-50, 55-60,70-80 bpm
FILLING ACCURACY	≤±1-2% ml-gm	≤±1-3% ml-gm	≤±1-4% ml-gm	≤±1-6% ml-gm
HOPPER VOLUME	100-150 letter/ kg	100-150 letter/ kg	100-150 letter/ kg	100-150 letter/ kg

FULLY AUTOMATIC SERVO BASE OPERATED LIQUID MACHINE

(USE FOR VISCOSITY FOR WATER TO HONEY LEVEL)

BN-ENTERPRISES

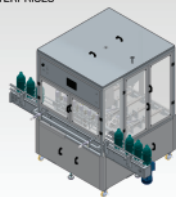

MODEL	bntpalf: 10-100 ml-gm 2h-4h-6h-8h-10h-12h	bntpalf:50-500 ml -gm 2h-4h-6h-8h-10h-12h	bntpalf:100-1000 ml -gm 2h-4h-6h-8h-10h-12h	bntpalf:500-5000 ml -gm 2h-4h-6h-8h-10h-12h
POWER	2.5 kw 230 ac 50hz 3 kw 230 ac 50hz 3.5 kw 230 ac 50hz 4 kw 230 ac 50hz 4.5 kw 230 ac 50hz 5 kw 230 ac 50hz	2.5 kw 230 ac 50hz 3 kw 230 ac 50hz 3.5 kw 230 ac 50hz 4 kw 230 ac 50hz 4.5 kw 230 ac 50hz 5 kw 230 ac 50hz	2.5 kw 230 ac 50hz 3 kw 230 ac 50hz 3.5 kw 230 ac 50hz 4 kw 230 ac 50hz 4.5 kw 230 ac 50hz 5 kw 230 ac 50hz	2.5 kw 230 ac 50hz 3 kw 230 ac 50hz 3.5 kw 230 ac 50hz 4 kw 230 ac 50hz 4.5 kw 230 ac 50hz 5 kw 230 ac 50hz
AIR PRESSURE	4 to 6 bar	4 to 6 bar	4 to 6 bar	4 to 6 bar
FILLING SPEED	20-25,35-40,45-50,55-60, 75-80,85-90 bpm	20-25,35-40,45-50,55-60, 75-80,85-90 bpm	20-25,35-40,45-50,55-60, 75-80,85-90 bpm	20-25,35-40,45-50,55-60, 75-80,85-90 bpm
FILLING ACCURACY	≤±1-2% ml-gm	≤±1-2% ml-gm	≤±1-2% ml-gm	≤±1-2% ml-gm
HOPPER VOLUME	100-150 letter/ kg	100-150 letter/ kg	100-150 letter/ kg	100-150 letter/ kg

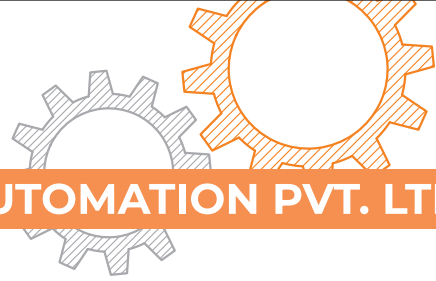

FULLY AUTOMATIC PNEUMATICS OPERATED PASTE FILING MACHINE

(USE FOR VISCOSITY FOR WATER TO PASTE LEVEL)

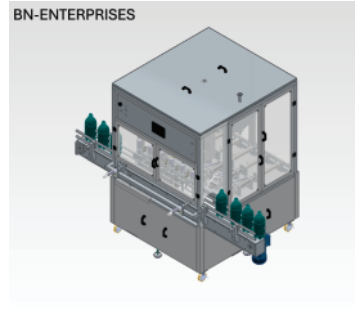

MODEL	BNTPAFPF: 10-100 ML-GM 2H-4H-6H-8H-10H-12H	BNTPAFPF:50-500 ML -GM 2H-4H-6H-8H-10H-12H	BNTPAFPF:100-1000 ML -GM 2H-4H-6H-8H-10H-12H	BNTPAFPF:500-5000 ML -GM 2H-4H-6H-8H-10H-12H
POWER	1.2 kw 230 ac 50hz	1.2 kw 230 ac 50hz	1.2 kw 230 ac 50hz	1.2 kw 230 ac 50hz
AIR PRESSURE	4 to 6 bar	4 to 6 bar	4 to 6 bar	4 to 6 bar
FILLING SPEED	10-15,25-30,35-40,45-50, 55-60,70-80 bpm	10-15,25-30,35-40,45-50, 55-60,70-80 bpm	10-15,25-30,35-40,45-50, 55-60,70-80 bpm	10-15,25-30,35-40,45- 50,55-60,70-80 bpm
FILLING ACCURACY	≤±1-2% ml-gm	≤±1-3% ml-gm	≤±1-4% ml-gm	≤±1-6% ml-gm
MACHINE DIMENSION L X W X H	950x320x340mm 1230x470x350mm	920x285x275 mm 920x485x275 mm	1320x285x275 mm 1320x485x275 mm	950x320x340mm 1230x470x350mm
WEIGHT	100-150 letter/ kg	100-150 letter/ kg	100-150 letter/ kg	100-150 letter/ kg

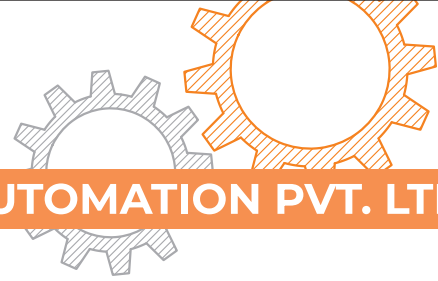

FULLY AUTOMATIC SERVO BASE OPERATED PASTE FILING MACHINE

(USE FOR VISCOSITY FOR WATER TO PASTE LEVEL)

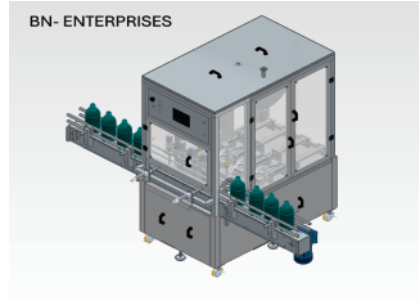

MODEL	BNTPALF: 10-100 ML-GM 2H-4H-6H-8H-10H-12H	BNTPALF:50-500 ML -GM 2H-4H-6H-8H-10H-12H	BNTPALF:100-1000 ML -GM 2H-4H-6H-8H-10H-12H	BNTPALF:500-5000 ML -GM 2H-4H-6H-8H-10H-12H
POWER	2.5 kw 230 ac 50hz 3 kw 230 ac 50hz 3.5 kw 230 ac 50hz 4 kw 230 ac 50hz 4.5 kw 230 ac 50hz 5 kw 230 ac 50hz	2.5 kw 230 ac 50hz 3 kw 230 ac 50hz 3.5 kw 230 ac 50hz 4 kw 230 ac 50hz 4.5 kw 230 ac 50hz 5 kw 230 ac 50hz	2.5 kw 230 ac 50hz 3 kw 230 ac 50hz 3.5 kw 230 ac 50hz 4 kw 230 ac 50hz 4.5 kw 230 ac 50hz 5 kw 230 ac 50hz	2.5 kw 230 ac 50hz 3 kw 230 ac 50hz 3.5 kw 230 ac 50hz 4 kw 230 ac 50hz 4.5 kw 230 ac 50hz 5 kw 230 ac 50hz
AIR PRESSURE	4 to 6 bar	4 to 6 bar	4 to 6 bar	4 to 6 bar
FILLING SPEED	20-25,35-40,45-50,55-60, 75-80,85-90 bpm	20-25,35-40,45-50,55-60, 75-80,85-90 bpm	20-25,35-40,45-50,55-60, 75-80,85-90 bpm	20-25,35-40,45-50,55-60, 75-80,85-90 bpm
FILLING ACCURACY	≤±1-2% ml-gm	≤±1-2% ml-gm	≤±1-2% ml-gm	≤±1-2% ml-gm
MACHIN DIMENSION L X W X H	950x320x340mm 1230x470x350mm	920x285x275 mm 920x485x275 mm	1320x285x275 mm 1320x485x275 mm	950x320x340mm 1230x470x350mm
WEIGHT	100-150 ltr/ kg	100-150 ltr/ kg	100-150 ltr/ kg	100-150 ltr/ kg

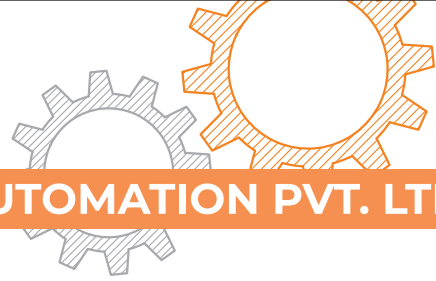

SEMI AUTO POWDER FILLING

(USE FOR VISCOSITY FOR POWDERS TO GRANULES DRY PRODUCTS)



MODEL	BNTPASPF-1 TO 100GM	BNTPASPF-2 TO 200GM	BNTPASPF-10 TO 1000GM	BNTPASPF-10 TO 3000GM
POWER SUPPLY	200w 230 v ac 50hz	200w 230 v ac 50hz	80w 230 v ac 50hz	80w 230 v ac 50hz
WEIGHING RANGE	1-100gm	2-200	10-1000gm	50-5000gm
ACCURACY	within1-+2gm	within1-+2gm	within1-+2gm	within1-+2gm
DISPENSING SPEED	10-15 times/min	10-15 times/min	10-15 times/min	10-15 times/min
HOPPER CAPACITY	1 to 2 kg	1 to 2 kg	1 to 5 kg	1 to 6 kg
MACHINE DIMENSION	700x420x1260mm	700x420x1260mm	420x320x550mm	420x320x550mm
WEIGHT	8kg	8kg	60kg	80kg

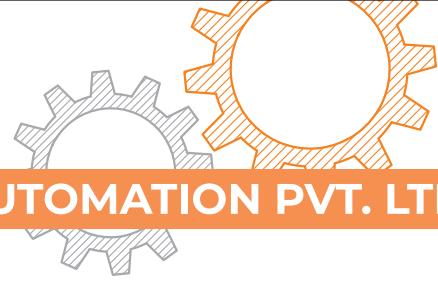

FULLY AUTO POUCH PACKAGING MACHINE

(USE FOR VISCOSITY FOR POWDERS TO GRANULES DRY PRODUCTS)



MODEL	BNTPAFPF-1 TO 100GM	BNTPAFPF-2 TO 200GM	BNTPAFPF-10 TO 1000GM	BNTPAFPF-10 TO 3000GM
POWER SUPPLY	1kw 230 v ac 50hz	1.2 w 230 v ac 50hz	1.5 w 230 v ac 50hz	2kw 230 v ac 50hz
WEIGHING RANGE	1-100gm	2-200	10-1000gm	50-5000gm
ACCURACY	within 2g	within 2g	within 2g	within 2g
POUCH SELLING TYPES	center sell /side sell/4 side sell	center sell /side sell/4 side sell	center sell /side sell/4 side sell	center sell /side sell/4 side sell
NO HEAD	1h/2h/4/	1h/2h/4/	1h/2h/4/	1h/2h/4/
SPEED PAR MINUET OF POUCH	10-15/-15-25/30-40	10-15/-15-25/30-40	10-15/-15-25/30-40	10-15/-15-25/30-40
HOPPER CAPACITY	1 to 2 kg	1 to 2 kg	1 to 5 kg	1 to 6 kg

HORIZONTALFLOW WRAP SERVO MACHINE

MODEL	BNTPAHFW-350RW	BNTPAHFW-450RW
POWER SUPPLY	4 kw 230 v ac 50hz	4.5 kw 230 v ac 50hz
POUCH SIZE	65 mm -330 mm max	65-330
FILM ROLL WIDTH	up to 340 mm	up to 440 mm
PRODUCT HEIGHT	up to 60 mm	up to 80 mm
SPEED PAR MINUET POUCH	40 to 100 nos	40 to 100 nos
DRIVE TYPES	belt/push hook	belt/push hook



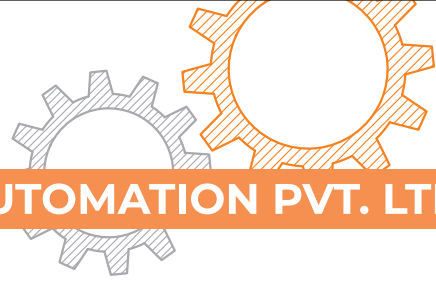

CONTINUOUS BAND SEALING MACHINE



MODEL	BNTPAFR-880H	BNTPAFR-880V	BNTPAFR-880HN	BNTPAFR-880HN
POWER SUPPLY	850w 230 v ac 50hz	850w 230 v ac 50hz	850w 230 v ac 50hz	850w 230 v ac 50hz
SEALING WIDTH	up to 12 mm	up to 12 mm	up to 12 mm	up to 12 mm
TEMPERATURE	0-300 c	0-300 c	0-300 c	0-300 c
MOC	MS/ss	MS/ss	MS/ss	MS/ss
BELT SPEED	up to 12 Mtr	up to 12 Mtr	up to 12 Mtr	up to 12 Mtr
CAPACITY	10gm-5kg	10gm-5kg	10gm-5kg	10gm-5kg

MANUAL HAND SEALING MACHINE



MODEL	BNTPA-200L	BNTPA-300L	BNTPA-400L
POWER SUPPLY	250w 230 v ac 50hz	350w 230 v ac 50hz	450w 230 v ac 50hz
SEALING WIDTH	2 mm	2 mm	2 mm
SEALING LENGTH	200 mm (8")	300 mm (12")	400 mm (16")
MACHINE DIMENSION	890x420x380mm	890x420x550 mm	890x420x380mm

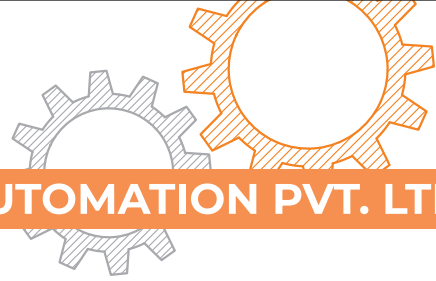

VACUUM PACKING MACHINE



MODEL	BNTPA-260DZ	BNTPA-300DZ	BNTPA-400DZ	BNTPA-500DZ	BNTPA-600DZ
POWER SUPPLY	850w 230 v ac 50hz	850w 230 v ac 50hz	850w 230 v ac 50hz	850w 230 v ac 50hz	850w 230 v ac 50hz
SEALING WIDTH & LENGTH	8-10 /260 mm	8-10/ 300 mm	8-10 /400 x2	8-10 / 500 mm x2	8-10 /600 mm x2
PRODUCTION SPEED	2-4 times/min	2-4 times/min	2-4 times/min	2-4 times/min	4-10 times/min
CHAMBER SIZE	320*270*57mm				

VACUUM PACKING MACHINE EXTERNAL WITH NITROGEN FILLING



MODEL	BNTPA-500DZ	BNTPA-500DZ	BNTPA-600DZ	BNTPA-600DZ
POWER SUPPLY	850w 230 v ac 50hz	850w 230 v ac 50hz	850w 230 v ac 50hz	850w 230 v ac 50hz
SEALING WIDTH & LENGTH	8-10 / mm	8-10/ 300 mm	8-10 /400 x2	8-10 / 500 mm x2
PRODUCTION SPEED	2-4 times/min	2-4 times/min	2-4 times/min	2-4 times/min
CHAMBER SIZE	320*270*57mm			
MOC	MS	ss	MS	ss

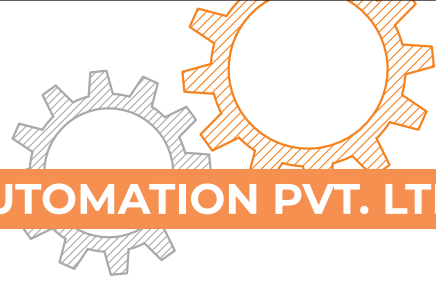

LABEL APPLICATOR MACHINE

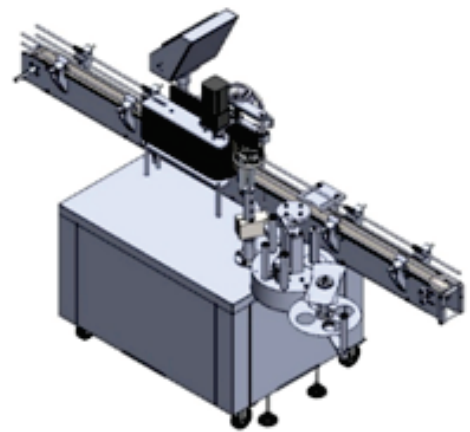
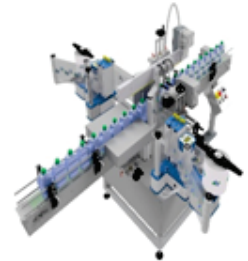

MODEL NO	BNTPAR-30100150-250 STEPPER/SERVO	BNTPAFB-30150-250 STEPPER/SERVO	BNTPAFBR-30150-250 STEPPER/SERVO	BNTPAFS-30150-250 STEPPER/SERVO	BNTPAT-30150-250 STEPPER/SERVO
SPEED BPM	30-40/50-80	30-40/50-80	30-40/50-80	30-40/50-80	30-40/50-80
LABEL ROLL DIA.	up to 300 mm	up to 300 mm	up to 300 mm	up to 300 mm	up to 300 mm
LABEL ACCURACY	± 1-3 /1-2 mm	± 1-3 /1-2 mm	± 1-3 /1-2 mm	± 1-3 /1-2 mm	± 1-3 /1-2 mm
CORE INNER DIA.	75/76 mm	75/76 mm	75/76 mm	75/76 mm	75/76 mm
GAP BETWEEN TWO LABELS	3 to 4 mm	3 to 4 mm	3 to 4 mm	3 to 4 mm	3 to 4 mm
APPLICATOR FOR TYPES	round	front & back	front back & round	one side	top side
MACHINE OPERATED	plc & hmi stepper/servo	plc & hmi stepper/servo	plc & hmi stepper/servo	plc & hmi stepper/servo	plc & hmi stepper/servo
APPLICATOR LABEL SIZE LENGTH ANY SIZE	h 30-150/30-250 mm	h 30-150/30-250 mm	h 30-150/30-250 mm	h 30-150/30-250 mm	h 30-150/30-250 mm
POWER SUPPLY	1 kw 230 v ac 50hz	1.5 kw 230 v ac 50hz	1.7 kw 230 v ac 50hz	0.5 kw 230 v ac 50hz	1 kw 230 v ac 50hz
MATERIAL OF CONSTRUCTION	MS/ss 304	MS/ss 304	MS/ss 304	MS/ss 304	MS/ss 304



ROPPCAPPING MACHINE:



MODEL	BNTPA-2040D-1H	BNTPA-2040D-4H	BNTPA-2040-6H	BNTPA-2050DM	BNTPA-2050DSM
POWER SUPPLY	1.5kw 230 v ac 50hz	2.5w 230 v ac 50hz	3 kw 230 v ac 50hz	50w 230 v ac 50hz	180w 230 v ac 50hz
CAPPING DIMETER	up to 100 mm	up to 100 mm	up to 100 mm	20 to 50 mm	20 to 50 mm
PRODUCTION SPEED BPM	30-40 bpm	50-60 bom	70-80 bom	10 to 12 bpm	10 to 12 bpm
MOC	MS/ss304	MS/ss304	MS/ss304	toll	aluminum/MS/ss

INKJET PRINTER



MODEL	BNTPA-12.5 H/25H /50H/100H	BNTPA-12.5 H/25H/ 50H/100H	BNTPATIG-4"12.5H	BNTPATIG-7"12.5H
POWER SUPPLY	230 v ac 50hz	230 v ac 50hz	230 v ac 50hz	50w 230 v ac 50hz
OPERATING	handy manual	auto online	auto online	auto online
PRINT HEIGHT IN MM	12.5 /25/50/100	12.5 /25/50/100	12.5 /25/50/100	12.5 /25/50/100

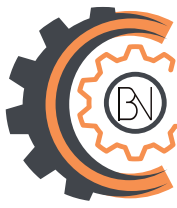

CODING MACHINE



MODEL	BNTPA-DY8	BNTPA-HP241-B	BNTPA-380FSS	BNTPA-380FMS
POWER SUPPLY	230 v ac 50hz	230 v ac 50hz	230 v ac 50hz	50w 230 v ac 50hz
OPERATING	handy manual	semi auto	automatic	automatic
PRINT NO OF LINE	3-4	3-4	3-4	3-4

INDUCTION SEALING

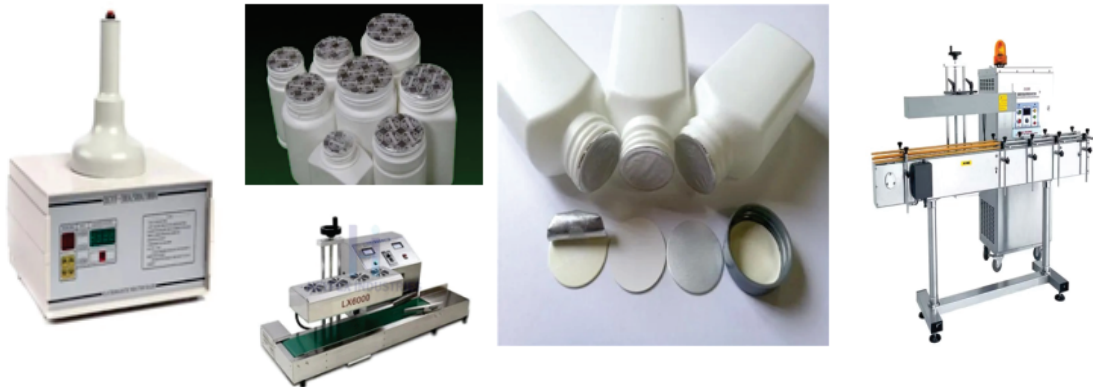

MODEL	BNTPA-200F	BNTPA-600C	BNTPA-20100D	BNTPA-60130D
POWER SUPPLY	500w 230 v ac 50hz	600 w 230 v ac 50hz	1kw 230 v ac 50hz	1.5 kw 50w 230 v ac 50hz
OPERATING	semi auto	semi auto	automatic	automatic
CAP SEALING DIMETER	20-100 mm	60-130 mm	20-100 mm	20-130mm
PRODUCTION SPEED	20-40 bpm	20-40 bpm	20-80 bpm	20-80 bpm

SEMI/AUTOMATIC CUP/GLASS SEALING MACHINE



MODEL	bntpa-140	bntpa-sc4-75d	bntpa-015sp	bntpa-3040sp
POWER SUPPLY	500w 230 v ac 50hz	800 w 230 v ac 50hz	1kw 230 v ac 50hz	1.5 kw50w 230 v ac 50hz
OPERATING	manual	semi auto	automatic indexing	automatic for online
NO OF CUP ROW & INDEXER	1x1	4x4	2-4x 5	4 x 60
CAP SEALING DIMETER	up-140 mm	up -100 mm	up-100 mm	up to 100 mm
PRODUCTION SPEED	5 -8 cpm	8-10cpm	10-15 cpm/ 30-40cpm	30-40cpm

SHRINK(TUNNEL) WRAPPING MACHINE

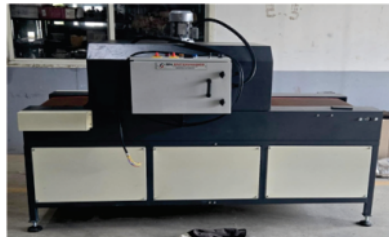

MODEL	bntpa-4525r/b	bntpa-4535r/b	bntpa-6045r/b	bntpa-4525mr/b	bntpa-4525er/b	bntpa-ss612/p
PRODUCTION SPEED	up to 60	up to 60	up to 60	up to 20	up to 40	up-40
HIT ZONE SIZE LxWxH	1000x450x250 1250x450x250	1000x450x350. 1250x450x350	1500x600x450	500x450x250	1000x450x250	1500x150x300
HEATER LODE CAPACITY	7 -9 kw	9-12 kw	15-19kw	5-7 kw	6-8 kw	12-16kw
CONVEYOR DRIVE TYPES	silicon roller / belt Teflon	silicon roller / belt Teflon	silicon roller / belt Teflon	silicon roller / belt Teflon	silicon roller / belt Teflon	ss slat
POWER SUPPLY	415 v ac 50hz	415 v ac 50hz	415 v ac 50hz	230 v ac 50hz	415 v ac 50hz	415 v ac
MODELS	heavy-duty	heavy-duty	heavy-duty	mini models	eco motels	heavy-duty
APPLICABLE FILM	pof/pvc/ldp	pof/pvc/ldp	pof/pvc/ldp	pof/pvc	pof/pvc	printed pvc slave

SEMIAUTO L- BAR SEALER



MODEL	BNTPA-2015-P	BNTPA-2015-PM	BNTPA-2015-PTA	BNTPA-2015-PTAM	BNTPA-2015-PTAP
PRODUCTION SPEED	8-10	10-12	10-12	12-15	13-18
SLING SIZE LXW	up to 500 up to 350	up to 500 up to 350	up to 500 up to 350	up to 500 up to 350	up to 500 up to 350
SELLING POWER	900 VA	900 VA	900 VA	900 VA	900 VA
PRODUCT TRAVEL	manual push	manual push	auto	auto	auto
POWER SUPPLY AIR SUPPLY	230 v ac	230 v ac	230 v ac	230 v ac	230 v ac 4-6 bar
APPLICABLE FILM	pof/pvc/ldp	pof/pvc/ldp	pof/pvc/ldp	pof/pvc/ldp	pof/pvc/ldp
MODELS	heavy-duty	heavy-duty	heavy-duty	heavy-duty	heavy-duty

CHAMBER TYPE SHRINK WRAPPING MACHINE



MODEL	BNTPA-2015-P	BNTPA-2015-M
PRODUCTION SPEED	5-8	6-10
SLING SIZE LXW	up to 500	up to 500 up to 350
SELLING POWER	up to 350	900 VA
POWER SUPPLY AIR SUPPLY	900 VA	3.5 kw 230 v ac
APPLICABLE FILM	3.5 kw 230 v ac	pof/pvc
MODELS	pof/pvc	heavy-duty
MACHINE DIMENSIONS (L X W X H)	heavy-duty	1500 x 800 x 1100 mm

1500 x 800 x 1100 mm

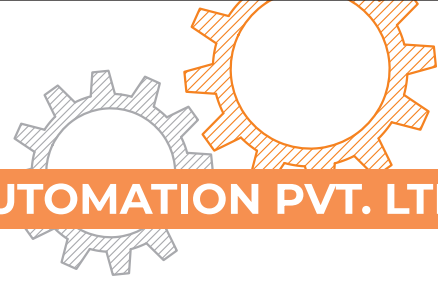

WEB SELLER & SHRINK SLAVE APPLICATOR



MODEL	BNTPA-W6045	BNTPA-WF6045	BNTPA-30150D
PRODUCTION SPEED	4-6	6-10	up -80 bom
SLING SIZE	700mm	700 mm	
SUITABLE PRODUCT	bottle/ teen /box .etc.	bottle/ teen /box .etc.	bottle / jar /teen
POWER SUPPLY AIR SUPPLY	3.5 kw 230 v ac	3.5 kw 230 v ac	2.2kw 415v 50 hz
APPLICABLE FILM	ldp	ldp	printed pvc live roll
MODELS	heavy-duty	heavy-duty	heavy-duty



FULLY AUTO L-BAR SEALER WITH SHRINK TUNNEL



MODEL NO	BNTPAFL-5545RL+ BNTPA-4525-B/R	BNTPAFL-5545PL+ BNTPA-4525-B/R	BNTPAFL-5545PLK+ BNTPA-4525-B/R	BNTPAFL-5545+ BNTPA-4525-B/R	BNTPAFL-6560TBD + BNTPA-5535-R/B
PRODUCTION SPEED	20-25 cpm	20-25 cpm	20-25 cpm	20-25 cpm	15-25 cpm
PRODUCT SELLING SIZE L×W×H	80-500 mm	80-500 mm	30-500 mm	80-500 mm	
	20-400 mm	20-400 mm	20-400 mm	20-400 mm	
	up-130 mm	up-130 mm	up-130 mm	up-130 mm	
POWER SUPPLY AIR SUPPLY	2.5 kw 230 v ac 50hz	2.5 kw 230 v ac 50hz	2.5 kw 230 v ac 50hz	2.5 kw 230 v ac 50hz	
APPLICABLE FILM	pof film	pof film	pof film	pof film	
MODELS	eco	heavy-duty	heavy-duty	heavy-duty	

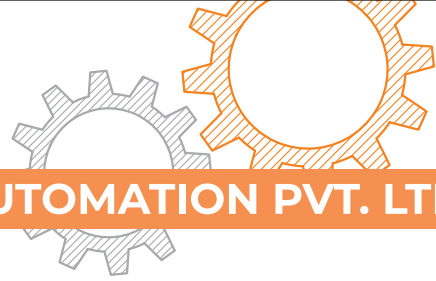

SIDE SEALER WITH SHRINK TUNNEL



MODEL NO	BNTPASLF-5580TBC +BNTPA-8560-B/R	BNTPASLF-5580TBC +BNTPA-8560-B/R			
PRODUCTION SPEED	20-25 cpm	20-25 cpm	20-25 cpm	20-25 cpm	25 c
PRODUCT SELLING SIZE L×W×H	80-500 mm	80-500 mm	30-500 mm	80-500 mm	
	20-400 mm	20-400 mm	20-400 mm	20-400 mm	
	up-130 mm	up-130 mm	up-130 mm	up-130 mm	
POWER SUPPLY AIR SUPPLY	2.5 kw 230 v ac 50hz	2.5 kw 230 v ac 50hz	2.5 kw 230 v ac 50hz	2.5 kw 230 v ac 50hz	
APPLICABLE FILM	pof film	pof film	pof film	pof film	
MODELS	eco	heavy-duty	heavy-duty	heavy-duty	

CARTON BOX TAPING MACHINE



MODEL NO	bntpa-4030	bntpa-6050	bntpa-6050r	bntpa-5050af	bntpa-6050+8060c
PRODUCTION SPEED	up-25 cpm	up-25 cpm	up-25 cpm	up-25 cpm	up-25 cpm
BOX SIZE L×W×H	120-up mm	200-up mm	200-up mm	200-up mm	200-up mm
	80-320 mm	160 -500 mm	160 -500 mm	160 -500 mm	160 -500 mm
	90-400 mm	150-600mm	150-600mm	150-500 mm	150-600mm
POWER SUPPLY AIR SUPPLY	0.18 kw 230 v ac 50hz	0.18 kw 230 v ac 50hz	0.18 kw 230 v ac 50hz 4-6 bar	1.5 kw 230 v ac 50hz 4-6 bar	2.5 kw 415 v ac
WIDTH BOPP/STRAP	25-75 mm	25-75 mm	25-75 mm	25-75 mm	25-75 mm 9 mm /12 mm
OPERATING TYPES	semiauto	semiauto	automatic	automatic	automatic

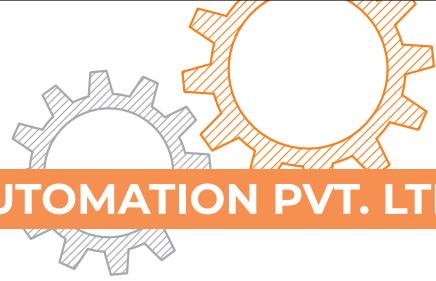
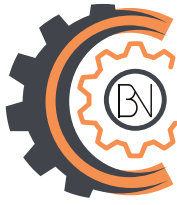

SEMI AUTOMATIC CARTON STRAPPING MACHINE



MODEL NO	BNTPA-XT8020	BNTPA-316H	BNTPA-PW8060C	BNTPA-8060R/B
PRODUCTION SPEED	up-25 cpm	up-25 cpm	up-25 cpm	up-25 cpm
BOX SIZE L×W×H	up – no limit	up – no limit	up –no limit up -800 mm up-600 mm customize size available	up –no limit up -800 mm up-600 mm customize size available
POWER SUPPLY AIR SUPPLY	0.18 kw 230 v ac 50hz	0.18 kw 230 v ac 50hz	0.18 kw 230 v ac 50hz 4-6 bar	1.5 kw 230 v ac 50hz 4-6 bar
WIDTH OF STRAP	6-19 mm	6-19 mm	9-12 mm	9-12 mm
OPERATING TYPES	semiauto	semiauto	automatic	automatic

PET STRAP TOOL



MODEL	BNTPA-AQD19	BNTPA-		
PRODUCTION SPEED	up-15 cpm	up-15 cpm	up-15 cpm	up-15 cpm
BATTERY OPERATED AIR SUPPLY	4-6 bar	battery operated		
WIDTH OF STRAP	12-19 mm		9-12 mm	9-12 mm
OPERATING TYPES	semiauto	semiauto	automatic	automatic

BOX/PALLET STRETCH WRAPPING MACHINE



MODEL	BNTPAP-1500D2000H/ 1600D2500H	BNTPAB-6060DH-PT	BNTPA-6060DH-ORB-AUTO /MANUAL
PRODUCTION SPEED	up-6 cpm	up-10 cpm	up-8 cpm
BOX SIZE L×W×H	500-1600mm 500-mm 300-25000 mm	200-600 mm 160 -600 mm 150-600 mm	300-up no limit 160 -600 mm 150-600mm
POWER SUPPLY	3 kw 230 /415 v ac 50hz	0.5 .1 , 1.5 kw 230 v ac 50hz	0.75,2.5 kw 230 v ac 50hz
WIGHT CARING CAPACITY	up to 1.5 tan	up to 60 kg	up to 200 kg
AIR SUPPLY		4-6 bar	4-6 bar
FILM HEIGHT & MICRON	300-600 mm 23-55 micron	300-600 mm 23-55 micron	100-200 mm 23-55 micron
OPERATING TYPES	fully auto	semiauto/ fully auto	semiauto/ fully auto



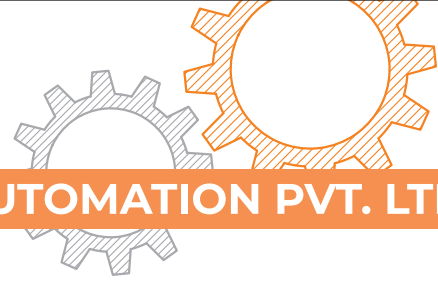

CUSTOMIZE CONVEYOR SYSTEMS: TYPES OF CONVEYOR

MODEL NO	BNTPA-PU/PVC/ TEFLON / RUBBER/ SILICON –FLAT INCLINE	BNTPA-SLAT SS/PP SLAT -FLAT INCLINE	BNTPA- MODULAR- FLAT INCLINE	BNTPA-MS MESH BELT / SS MESH BELT	BNTPA- TELESCOPIC CONVEYOR/3S-4/5.4M -7/9.6M
CONVEYOR SPEED	as par requirement	as par requirement	as par requirement	as par requirement	15-30 m min
CONVEYOR SIZE L×W×H	as par requirement	as par requirement	as par requirement	as par requirement	9600-16600 mm 600-800 mm 750- up mm
POWER SUPPLY	230 /415 v ac 50hz	230 /415 v ac 50hz	230 /415 v ac 50hz	230 /415 v ac 50hz	415 v ac 50 hz
WIGHT CARING CAPACITY	as par requirement	as par requirement	as par requirement	as par requirement	max lode 50 kg par Mtr
CONVEYOR USING APPLICATION	loading unloading product moments assembly work any customize purpose	loading unloading product moments assembly work any customize purpose	loading unloading product moments assembly work any customize purpose	loading unloading product moments assembly work any customize purpose	loading unloading product moments assembly work any customize purpose
MOC	MSpowder coated /ss/aluminum profile	MSpowder coated /ss/aluminum profile	MSpowder coated /ss/aluminum profile	MSpowder coated /ss/aluminum profile	MSpowder coated
OPERATING TYPES	fully auto / semi auto	fully auto / semi auto	fully auto / semi auto	fully auto / semi auto	fully auto / semi auto

SPM & AUTOMATION

all types of packing end line, all types of assembly pic & plash, ilk test ring machine,
customizespecial purpose machine,

CARTON ERECTOR & CARTING MACHINE

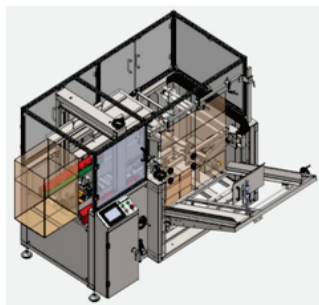

MODEL NO	BNTPAFCE-4540	BNTPAFCDU-3030	BNTPASCDU-3030	BNTPAFCE-100100AZ
SPEED	8-12 cpm	15-100 cpm	10-20 cpm	6-10 cpm
BOX /CARTON SIZE L X W X H	250-450 mm	25-300 mm	25-300 mm	450-1000 mm
	150-400 mm	25-300 mm	25-300 mm	400-1000 mm
	150-400 mm	10-50 mm	10-50 mm	400-1000 mm
BOX TYPES	corrugated box 3p, 5p,7p,	duplex box	duplex box	corrugated box 3p,5p,7p,
MACHINE OPERATING	fully auto	fully auto	semi auto	fully auto
POWER SUPPLY	230 /415 v ac 50hz	230 /415 v ac 50hz	230 /415 v ac 50hz	230 /415 v ac 50hz

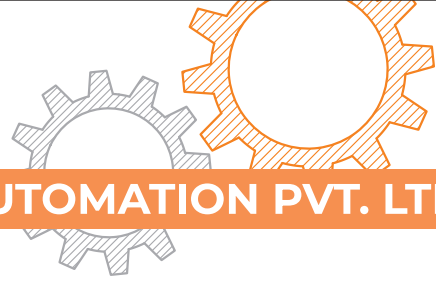

CUSTOMIZE CONVEYOR SYSTEMS: TYPES OF CONVEYOR



MODEL	bntpafb-1050k1-2h	bntpasbm-1050k1-2h	bntpaw-4-14h	bntpabtc-30070wh
SPEED	1-6 bag	1-6 bag	25-80	5 -10
BAG SIZE L X W X H	450-1000 mm 150-700 mm 300-1000 mm	450-1000 mm 150-700 mm 300-1000 mm		450-1000 mm 150-700 mm 300-1000 mm
BAG TYPES	as par your input	as par your input	as par your input	as par your input
WEIGHING CAPACITY	10-50 kg	10-50 kg	10 gm - 2 kg	100-300 kg
WEIGHING ACCURACY	3 to 15 gm - +	3 to 15 gm - +	+0.2 to 3 gm	
MACHINE OPERATING	fully auto	semi auto	semi auto	semi auto
POWER SUPPLY	230 /415 v ac 50hz	230 /415 v ac 50hz	230 /415 v ac 50hz	230 /415 v ac 50hz

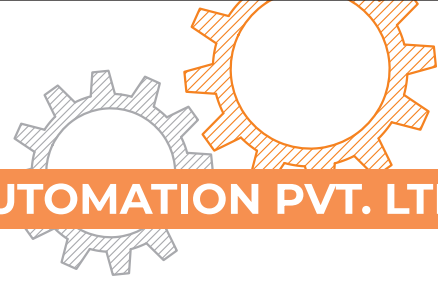

PACKAGING CONSUMABLE MATERIAL



POF SHRINK FILM



PVC SHRINK FILM



STRETCH FILM



POF SHRINK FILM POUCH



PVC SHRINK FILM POUCH



BUBBLE ROLLS



PET STRAPROLL



PP STRAPROLL



BOPP TAPE

MODEL	BNTPA-POF SHRINK FILM	BNTPA-STRAP ROLL	BNETPA-PET STRAP	BNTPA-LDPE SHRINK ROLL
ROLL SIZE IN INCH	8"-40"	9-12 w mm	9- 27 w mm	as par size
MICRON	15,19,25			30 to 100 micron
TICK		0.5 to 1 mm	0.7 to 2 mm	
LENGTH IN MATER	1332, 10800, 800 Mtr par roll	700 to 1200 Mtr		

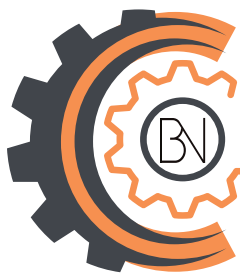
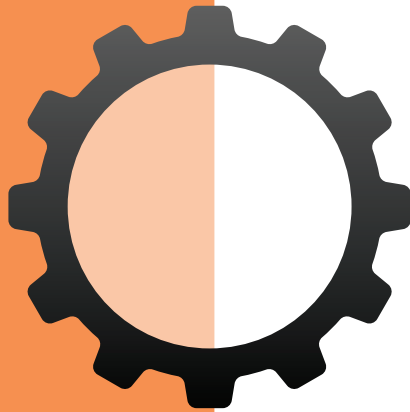

TECPACK AUTOMATION Pvt Ltd

Total Packing Solutions & Industrial Automation

B N TECPACK AUTOMATION PVT. LTD.

 +918308746511/9607993690

info@bntecpackautomation.com

 sales@bntecpackautomation.com
bntecpackautomation.com

 GateNo.20,NearKhedshivapurIndustrialEstate,
KondhanpurRoad,ArviVillage,Pune-412205(MH) INDIA